

4

3

2

1

REVISION HISTORY	
DESIGN REVISIONS AND REVISION LEVELS FOLLOW BASE PRODUCTION PART DOCUMENTATION	
SEE REVISION LEVEL IN TITLE BLOCK BELOW	

CUSTOMER PRINT
RELEASED FOR
EXTERNAL USE

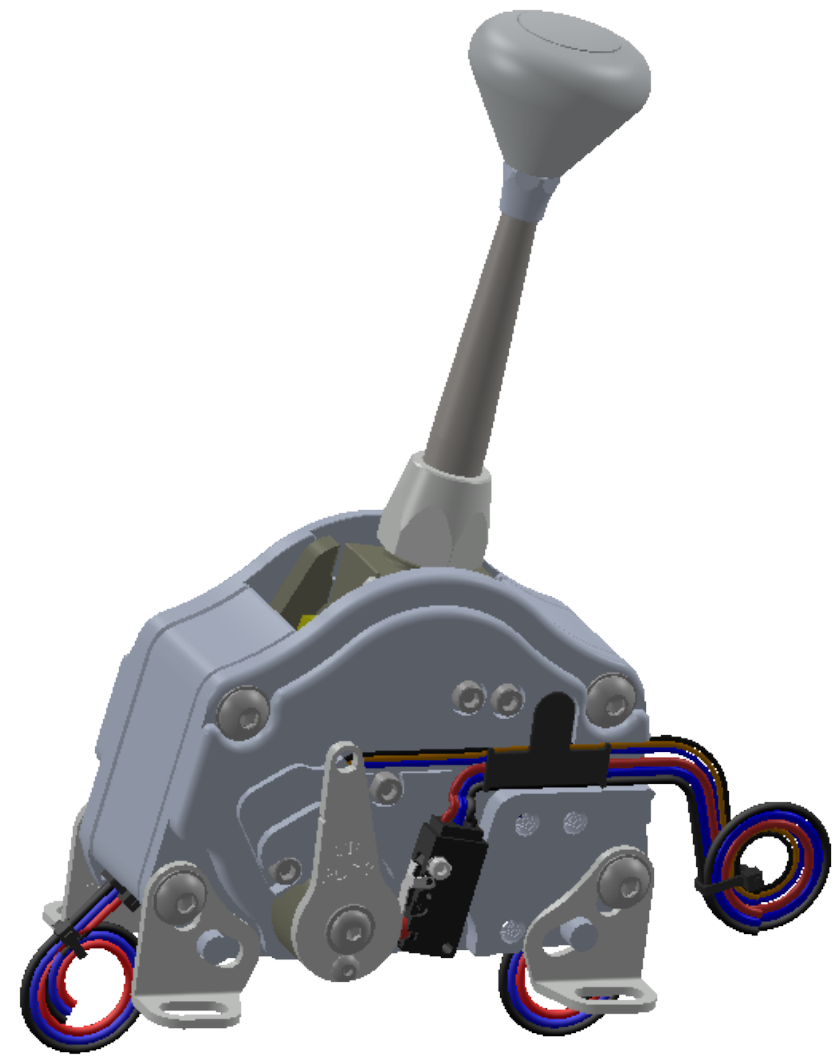
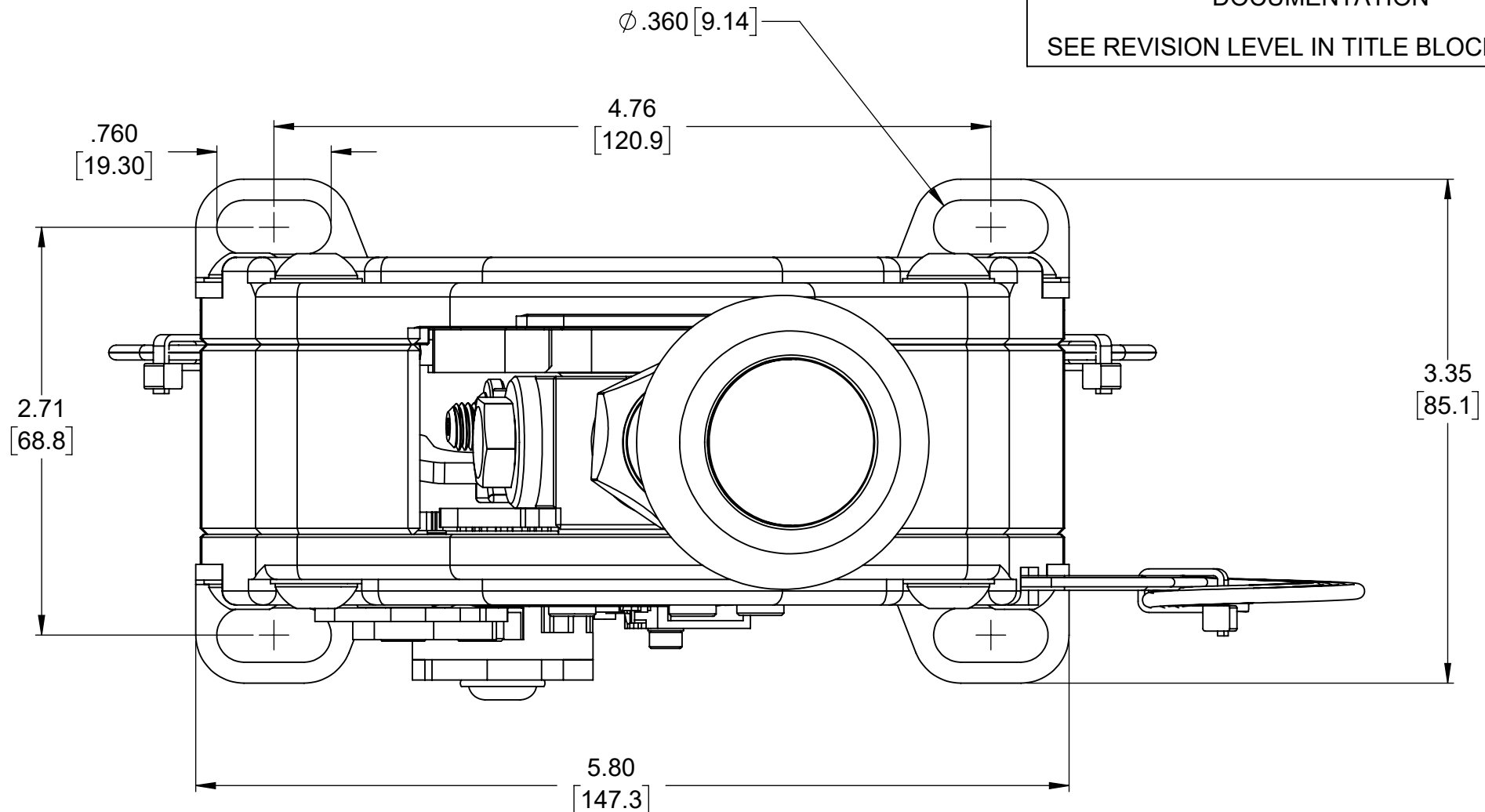

PROPRIETARY AND CONFIDENTIAL
THE INFORMATION CONTAINED IN THIS
DRAWING IS THE SOLE PROPERTY OF
LOKAR INC. ANY REPRODUCTION IN PART
OR AS A WHOLE WITHOUT THE WRITTEN
PERMISSION OF
LOKAR INC. IS PROHIBITED.

MATERIAL:

FINISH:

UNLESS OTHERWISE SPECIFIED
TOLERANCES ARE INCHES

ANGULAR: MACH $\pm 0.01^\circ$ BEND $\pm 1.0^\circ$
TWO PLACE DECIMAL: ± 0.010
THREE PLACE DECIMAL: ± 0.005
FOUR PLACE DECIMAL: ± 0.002

THIRD ANGLE PROJECTION

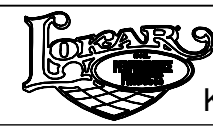
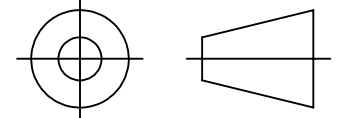

LOKAR, INC.
2545 QUALITY LANE
KNOXVILLE, TN 37931

ESS2 MOUNTING PATTERN

SIZE: DWG. NO:	B	ESXXXXXX	CUSTOMER	REV: A
SCALE: 1:1	WEIGHT: (LBS.)	3.656	SHEET: 5 OF 5	

4

3

2

1

D

D

C

C

B

B

A

A